

**Specifications:**

Type.....	10-23
Max. flow .....	800 US gpm
Dimensions L x W x H .....	89 x 41.3 x 52.3 inch
Surface treatment .....	Hot dip galvanized
Lifting point .....	Fitted with a single lifting point
Forklift pockets .....	Fitted with 2 forklift pockets
Stackable .....	Stackable for storage purposes
Branding panel L x H .....	35 x 20 inch
Connections.....	Optional (see auxiliary items)
Dry weight.....	1230 lbs. (560 kg)

**FEATURES**
**Mobile weir tank**

Settlement tanks are sand collectors to optimize your pumping system during dewatering projects. In addition to the collection and separation of sand present in the groundwater, settlement tanks also work as a deaerator to ensure an accurate flow measuring.

**Suitable for**

- Wellpoint dewatering
- Horizontal dewatering
- Construction dewatering
- Flow measuring
- pH-neutral water 32 - 115 °F

**Flow meter prepared**

The settlement tank is standard prepared for optional installation of a 4-inch portable flow meter.

**Safety first**

the settlement tank comes standard with a composite grating cover to avoid accidents.

**Extendable partition**

Pull-out partition for easily emptying of the settlement tank.

**Your own branding**

A large flat panel for your own company logo or contact details on both sides.

**MAXIMUM FLOW**
**Settlement tank with 6 inch discharge**
**max. flow**

10 feet 6 inch discharge line	800 gpm
20 feet 6 inch discharge line	640 gpm
30 feet 6 inch discharge line	570 gpm
40 feet 6 inch discharge line	530 gpm
60 feet 6 inch discharge line	485 gpm

**Settlement tank with 2 x 4 inch discharge**
**max. flow**

2 x 10 feet 4 inch discharge line	725 gpm
2 x 20 feet 4 inch discharge line	635 gpm
2 x 30 feet 4 inch discharge line	530 gpm
2 x 40 feet 4 inch discharge line	460 gpm
2 x 50 feet 4 inch discharge line	420 gpm

**Settlement tank with 4 inch discharge**
**max. flow**

10 feet 4 inch discharge line	335 gpm
20 feet 4 inch discharge line	315 gpm
30 feet 4 inch discharge line	295 gpm
40 feet 4 inch discharge line	270 gpm
50 feet 4 inch discharge line	250 gpm

**Settlement tank + flow meter with 4 inch discharge**
**max. flow**

10 feet 4 inch discharge line	330 gpm
20 feet 4 inch discharge line	310 gpm
30 feet 4 inch discharge line	285 gpm
40 feet 4 inch discharge line	265 gpm
50 feet 4 inch discharge line	240 gpm

Always read the user manual before use to ensure a safe and correct installation and for storage information.







**AUXILIARY ITEMS**
**Flow measuring**

Water flow measurement is most accurate with a de-aerated medium. This mobile settlement tank is therefore prepared for the use of the handy flow meter for optimal water management. BBA Pumps flow meters are available in all kinds of designs, from mechanical meters to digital flow meters and with various types of quick release couplings.

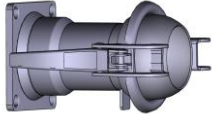
**Connections**

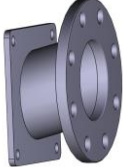
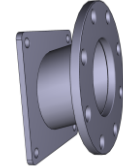
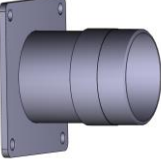
Mobile settlement tanks are supplied with square flanges on the inlet and outlet. We optionally supply the connections in various sizes and systems. Required: two (2) discharge connections and one (1) entrance connection.

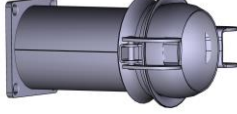
Art. Nr.	Description	Image
5032333	4" system B male (ball / lever)	
43727	4" system B female (cup)	
43723	4" DIN flange	
43726	4" ANSI flange	
43722	4" BSP thread	

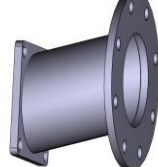
Art. Nr.	Description	Image
43728	6" system B Male (ball / lever)	
43725	6" system B female (cup)	
43630	6" DIN / ANSI flange	
5080601	Cover	